

CROWN DUO W3



ITEM DESCRIPTION

Crown DUO W3 is best for the illumination of shallow and medium depth (140-250mm) double-sided lightboxes. Equipped with advanced optic lenses these modules ensure uniform and bright illumination on different materials, like acrylic glass or textile of up to 2.5-meter height LED boxes. Thanks to the 24V system, more modules can be connected into one chain reducing voltage drops on long chains. Thus, giving availability to reduce electrical connections.

APPLICATION

- Double-sided light boxes with depth ranging from 140 to 250 mm
- Maximum height of light box 2 500 mm
- Bus shelters, billboards

FEATURES & BENEFITS

- 5-year warranty
- Integrated CC controller
- IP66 protection class
- Special optimised elliptical lens 15 x 45
- CRI 80
- 24 V solution

GENERAL SPECIFICATIONS

SUPPLY VOLTAGE	24 VDC
POWER	3.6 W
CRI	80
RECOMMENDED DEPTH	From 140 to 250 mm
CC DISTANCE	330 mm
BINNING	5 SDCM
OPERATING TEMPERATURE	-20 °C ~ +50 °C
STORAGE TEMPERATURE	-30 °C ~ +60 °C
STORAGE CONDITIONS	Relative humidity <60%
CERTIFICATION	CE, RoHS and ENEC compliant
IP CLASS	IP 66
LIFETIME	L80 50,000 h
WARRANTY	5 years*

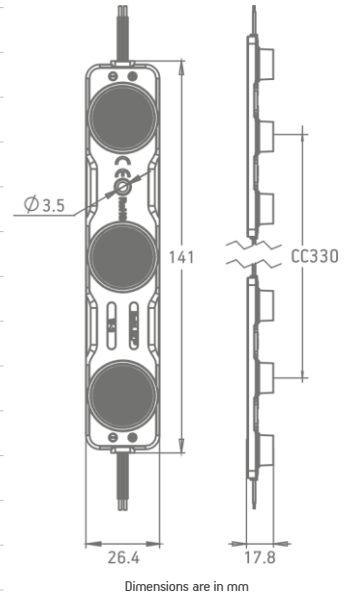

*Warranty is applied only and if storage, mounting and maintenance conditions, stated in the installation guide, are followed.

LIGHT DISTRIBUTION GRAPH

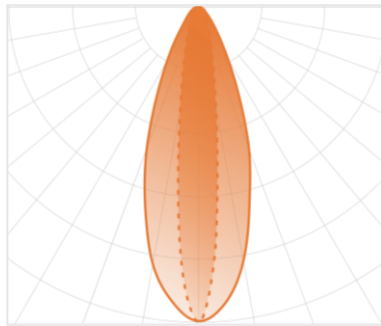

Beam angle: 15x45°

ORDERING INFORMATION

PRODUCT NAME	POWER, W	LUMEN OUTPUT, LM	COLOUR TEMP.	STATUS
BMP-W3-DS865E3.6	3.6	300	6500 K	PRE-ORDER*

* Pre-order products will be available only with MQQ – 1 box (320 pcs), lead time 3 – 4 weeks. For precise lead time, contact your Customer Service manager.

CHAIN	BAG	BOX
10 pcs (net weight: ~0.055 kg)	10 pcs (net weight: ~0.056 kg)	320 pcs (net weight: ~17.92 kg)